

D

C

B

A

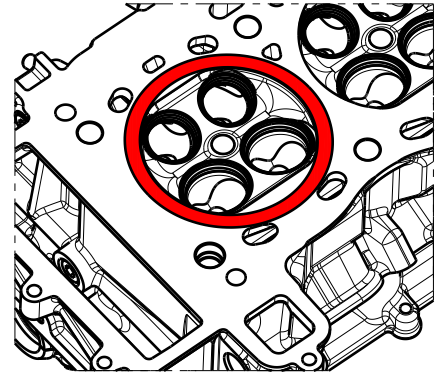

EXAMPLE

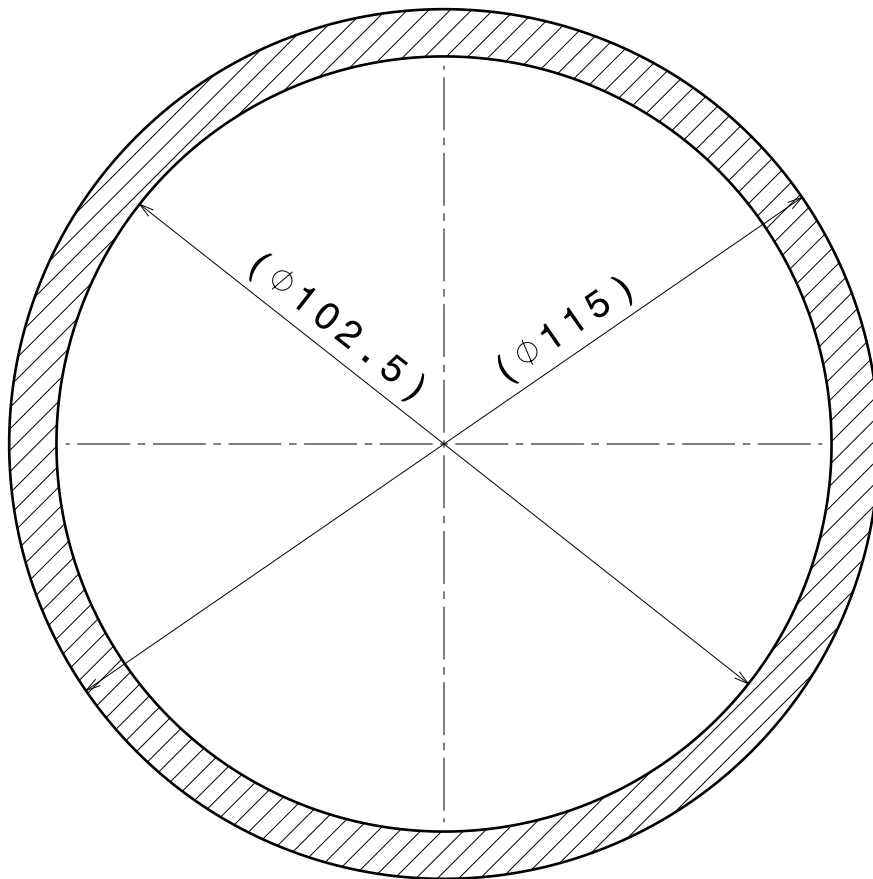

SEALING FACE TEMPLATE 'RING'  
Scale: 1:1

## INSTRUCTIONS:

- 1: PRINT THIS DRAWING AT A 1:1 SCALE
- 2: MEASURE THE DIAMETERS SHOWN ON THE PRINTED DRAWING TO CONFIRM IT HAS BEEN PRINTED ACCURATELY
- 3: CAREFULLY CUT-OUT THE HATCHED 'RING' WITH A KNIFE OR SCISSORS
- 4: LAY THE RING ON TO THE CYLINDER HEAD FIRE-FACE AND MANOEUVRE IT INTO A POSITION WHERE THERE ARE NO HOLES OR EDGES INTERSECTING WITH THE RING, AND ENSURE THE RING IS IN CONTACT WITH A FLAT SEALING FACE ON THE CYLINDER HEAD  
\*\*SEE EXAMPLE SHOWN\*\*

| REV. | DESCRIPTION          | DATE       | NAME         |
|------|----------------------|------------|--------------|
| 1    | EVOLUTION OF M1T0022 | 08/12/2023 | MARTIN JONES |

|  |  |
|--|--|
| UNSPECIFIED EDGES:<br>ISO 13715                | THREAD TOLERANCE:<br>UNLESS OTHERWISE STATED |
| $\begin{matrix} +0,3 \\ +0,2 \end{matrix}$     | $\begin{matrix} -0,2 \\ -0,3 \end{matrix}$   |
| METRIC 6H(INT) 6g(EXT)<br>INCH 2B(INT) 2A(EXT) |  |

|   |
|---|
| DRAWING STANDARDS:<br>BS 8888:2011  DIMENSIONS IN mm |
|---|

DRAWN BY:  
MARTIN JONES

EMAIL:  
MARTIN.JONES@MENTUMLIMITED.COM

PHONE:  
+44(0)7825 161263

DATE:  
08/12/2023

PART NUMBER:  
**M1T0030**

mentum limited

THIS DOCUMENT AND THE COPYRIGHT HEREIN ARE THE PROPERTY OF MENTUM LIMITED AND MAY NOT BE USED, COPIED OR DISCLOSED TO ANY THIRD PARTY WITHOUT THE WRITTEN CONSENT OF MENTUM LIMITED.

PART DESCRIPTION:  
**VOLUME MEASURING DISH - 102MM BORE**

|                    |                      |  |                  |
|--------------------|----------------------|--|------------------|
| SIZE:<br><b>A4</b> | SCALE:<br><b>1:1</b> | MATERIAL:<br>POLYCARBONATE (TRANSPARENT) | REV.<br><b>1</b> |
|--------------------|----------------------|--|------------------|

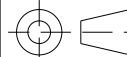
|                     |                    |   |            |
|---------------------|--------------------|---|------------|
| STATUS:<br>RELEASED | WEIGHT:<br>0.285kg |  | SHEET: 2/2 |
|---------------------|--------------------|---|------------|

D

A