

D

C

B

A

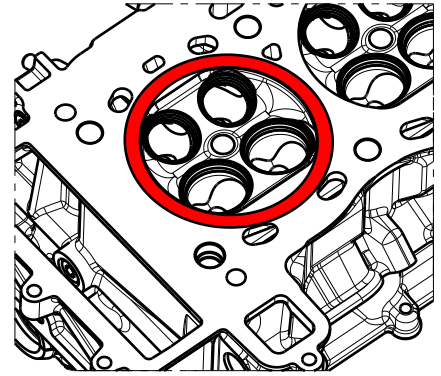
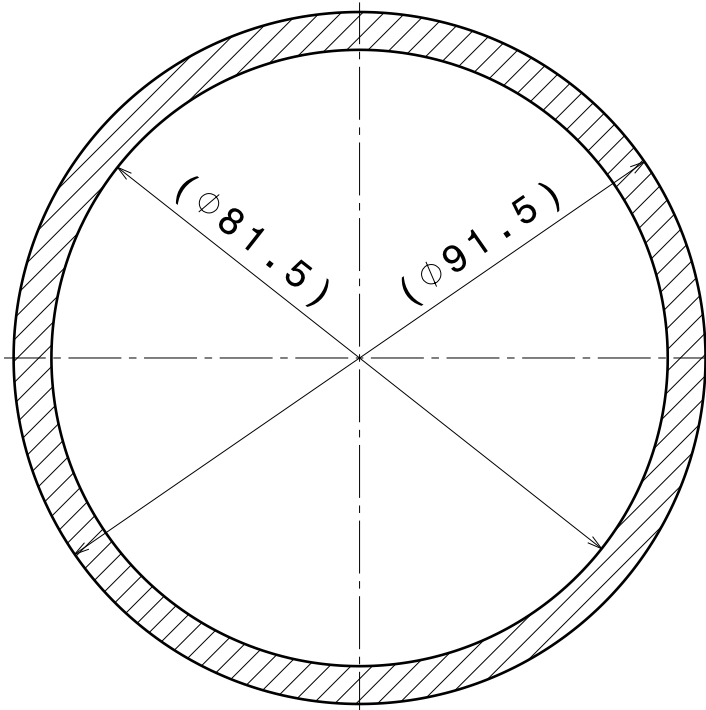

EXAMPLE

SEALING FACE TEMPLATE 'RING'
Scale: 1:1

INSTRUCTIONS:

- 1: PRINT THIS DRAWING AT A 1:1 SCALE
- 2: MEASURE THE DIAMETERS SHOWN ON THE PRINTED DRAWING TO CONFIRM IT HAS BEEN PRINTED ACCURATELY
- 3: CAREFULLY CUT-OUT THE HATCHED 'RING' WITH A KNIFE OR SCISSORS
- 4: LAY THE RING ON TO THE CYLINDER HEAD FIRE-FACE AND MANOEUVRE IT INTO A POSITION WHERE THERE ARE NO HOLES OR EDGES INTERSECTING WITH THE RING, AND ENSURE THE RING IS IN CONTACT WITH A FLAT SEALING FACE ON THE CYLINDER HEAD
SEE EXAMPLE SHOWN

REV.	DESCRIPTION	DATE	NAME
1	EVOLUTION OF M1T0003	06/12/2023	MARTIN JONES

UNSPECIFIED EDGES: ISO 13715	THREAD TOLERANCE: UNLESS OTHERWISE STATED
$\begin{matrix} +0,3 \\ +0,2 \end{matrix}$	$\begin{matrix} -0,2 \\ -0,3 \end{matrix}$
METRIC 6H(INT) 6g(EXT) INCH 2B(INT) 2A(EXT)	

PART NUMBER: M1T0021	mentum limited <small>THIS DOCUMENT AND THE COPYRIGHT HEREIN ARE THE PROPERTY OF MENTUM LIMITED AND MAY NOT BE USED, COPIED OR DISCLOSED TO ANY THIRD PARTY WITHOUT THE WRITTEN CONSENT OF MENTUM LIMITED.</small>
--------------------------------	---

DRAWING STANDARDS:
BS 8888:2011 $\triangle D$ DIMENSIONS IN mm

PART DESCRIPTION: VOLUME MEASURING DISH - 81MM BORE	
---	--

DRAWN BY:
MARTIN JONES

EMAIL:
MARTIN.JONES@MENTUMLIMITED.COM

SIZE: A4	SCALE: 1:1	MATERIAL: POLYCARBONATE (TRANSPARENT)	REV. 1
--------------------	----------------------	--	------------------

PHONE:
+44(0)7825 161263

DATE:
06/12/2023

STATUS: RELEASED	WEIGHT: 0.272kg		SHEET: 2/2
---------------------	-----------------	--	------------

D

A